

Application Highlight



Manufacturing | Water | Mechanical Seal

Application Info & Challenge

- **Industry:** Steel Manufacturing
- **Location:** Japan
- **Equipment:** QTY 1 Warman pump
- **Product:** Water 6% solids, 30 °C temperature
- **Speed:** 1200 RPM
- **Pressure:** 2.3 bar g



442C Split Seal

Previously packed application. Excessive sleeve wear and flush leakage.

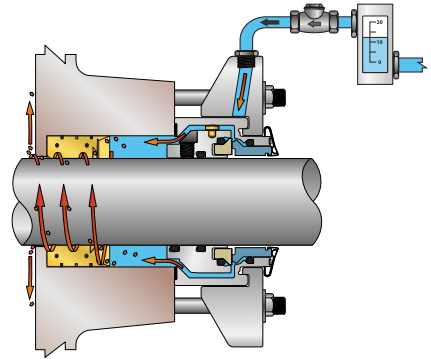

Solution & Result

- Chesterton 442C® Split Seal 90 mm SC/CB/FKM
- **SpiralTrac™** Version F Type S, made of ESC material

Installed with a plan 32 (clean external flush) setup. Seals installed without any startup leakage. In operation for 9 months (as of writing).



Version F SpiralTrac



Chesterton solution being installed

For more information please send an email to us at support@enviroseal.ca. We hope to hear from you!

