

# Application Highlight



Wastewater | Grit | Mechanical Seal

## Application Info & Challenge

- **Industry:** Wastewater
- **Location:** USA
- **Equipment:** QTY 2 Hayward Gordon XR3-11 pumps
- **Product:** Grit 0.5-2% solids, ambient temperature
- **Speed:** 1125 RPM
- **Pressure:** 1.1 bar g



442C Split Seal

Previously packed application. Excessive sleeve wear and leakage resulted in costly equipment damage and downtime.

## Solution & Result

- Chesterton 442C® Split Seal 2.000" SC/CB/FKM
- **SpiralTrac™** Version F Type S, made of ESC material

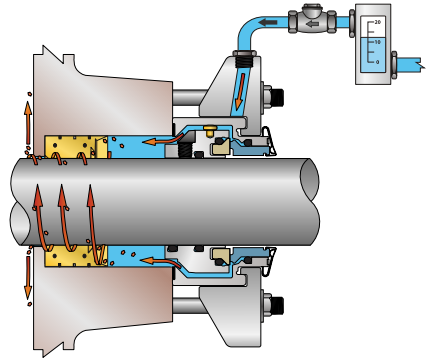

Installed with a plan 32 (clean external flush) setup. Seals installed without any startup leakage. In operation for 9 months (as of Jan 2023).



Version F SpiralTrac



Chesterton solution being installed

For more information please send an email to us at [support@enviroseal.ca](mailto:support@enviroseal.ca). We hope to hear from you!

