

Application Highlight



Manufacturing | Water | Mechanical Seal

Application Info & Challenge

- **Industry:** Steel manufacturing
- **Location:** Belgium
- **Equipment:** QTY 3 Ensival Moret CN 350-50 pumps
- **Product:** Water with metal particles, ambient temperature
- **Speed:** 1480 RPM
- **Pressure:** From 0.5 to 5.5 bar

Previously packed. Frequent packing adjustments, short MTBR. Excessive sleeve wear and leakage causing



No Flush



before



after



442 seal

Solution & Result

- Chesterton 442® Split Seal 90 mm SA RSC/CB S FKM
- **SpiralTrac™** Version N Type A

First installed January 2016, running leak free for 23 months (as of Dec 2017)!



SpiralTrac Version N Type A

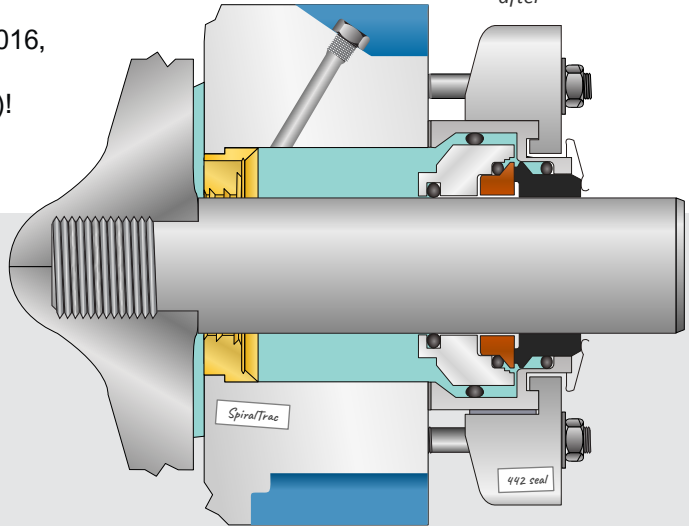

For more information please send an email to us at support@enviroseal.ca. We hope to hear from you!



2456 Rocky Lake Drive • Waverley • Nova Scotia • CANADA • B2R 1R6
+1 (902) 861-3464 • info@enviroseal.ca • enviroseal.ca

© 2023 EnviroSeal Engineering Products Ltd. • SpiralTrac™ is a trademark of EnviroSeal Engineering Products Ltd. • SS0061

