

Application Success Story:

Industry: Nickel Mining

Product: Lime

Sealing Solution: Packing

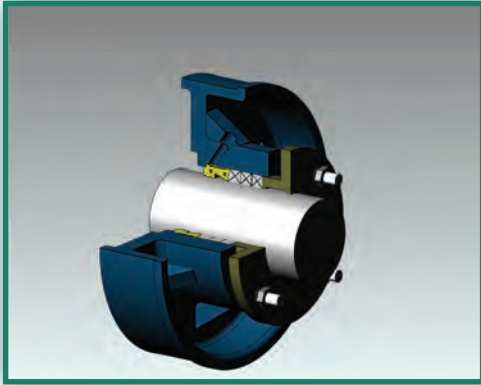

• Application Info

- Pump : Warman
- Model : 2 x 1 1/2
- Application: Regents Lime Pump
- Shaft Speed: 1450 RPM
- Product: Lime
- Solids: 30%
- Temp: 158-176°F (70-80°C)

• Problem

- Previous MTBR was 3-5 days
- The largest expense was lost production every time the pump went down.
- Over three months the repacks, downtime, labour and sleeves added up to \$11,606.60



• Solution

- SpiralTrac™ Version P Type A
- Part Number: PM04400RA06200(174) 10-0183
- Chesterton 477-1T 8mm Packing

• Result

- The new sealing solution cost \$3,120.55
- MTBR was extended by 18 times
- **Total cost savings over three months of \$8491.49**
- **Return on investment period three months!**

