

## Application Success Story:

**Industry: Fossil Power**

**Product: Lime Slurry**

**Sealing Solution: Mechanical Seal**

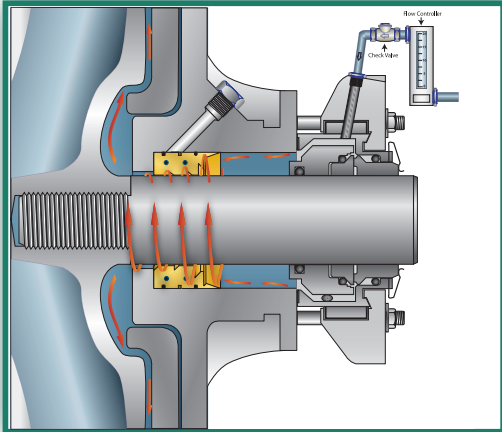

### • Application Info

- Warman
- Model : 650TU
- Application: Absorber Recycle
- Shaft Speed: 800 RPM
- Product: Lime Slurry
- Solids: 1.5% - 4.5%
- Temp: 80°F to 100°F / 26°C to 38°C
- Seal chamber pressure: 25-30 psi



### • Problem

- Previous seal required complete pump disassembly to change out and install a new seal. This required 4 men 4-5 days to perform and was extremely challenging and dangerous due to the size of the equipment.

### • Solution

- SpiralTrac™ Version F Type S
- Chesterton 442 mechanical seal (RSC-RSC-EP-SS)

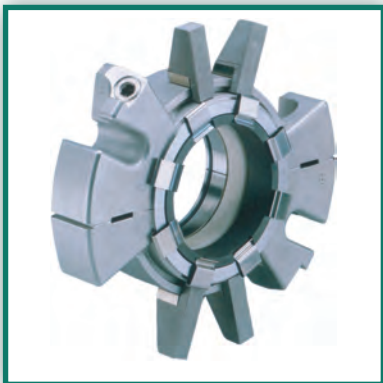

### • Result

- No pump disassembly is required to change the seal
- The seal can now be changed out by 2 men in 4 hours.
- All safety issues previously associated with the seal replacement have been eliminated!!!

