



## Application Success Story:

Industry: Pulp & Paper

Product: Wood Fiber

Sealing Solution: Packing

### Application Info

Equipment: Primary Refiners

Product: Wood Fiber

Shaft size: 14"

RPM: 1100

There are six double ended refiners equalling twelve stuffing boxes

### Problem

Excessive Flush Leakage

Excessive Product Leakage

Packing life of only two to four weeks

### Solution

Two **SpiralTrac™** Version P in each refiner part # PI14000RS15500(ESC) and part # PI14000LS15500(ESC) each installed with three rings of high quality packing

### Result

Greatly reduced flush leakage

Eliminated product leakage

The packing life **doubled** resulting in an annual savings of more than \$25,000 on packing costs alone

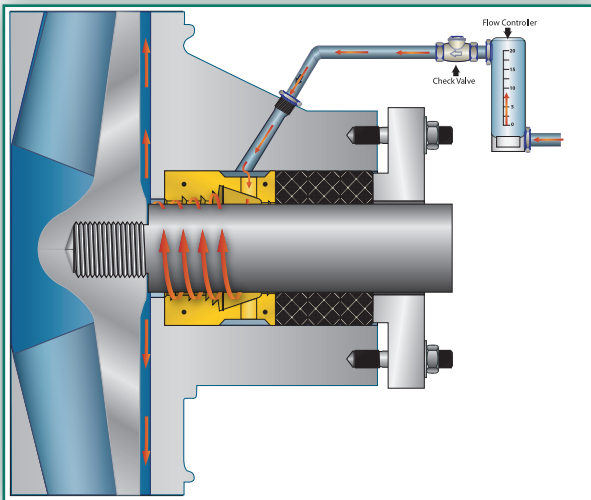

2456 Rocky Lake Drive  
Waverley, Nova Scotia B2R 1R6 CANADA  
(902) 861-3464 Fax: (902) 861-3522  
Email: sales@enviroseal.ca  
Website: www.enviroseal.ca

DISTRIBUTED BY:

Copyright ©2006  
EnviroSeal Engineering Products Ltd.

SpiralTrac is a trademark of EnviroSeal Engineering Products Limited.



ST01609-2401006