

Application Success Story:

Industry: **Chemical**

Product: **Acetate**

Sealing Solution: **Mechanical Seal**

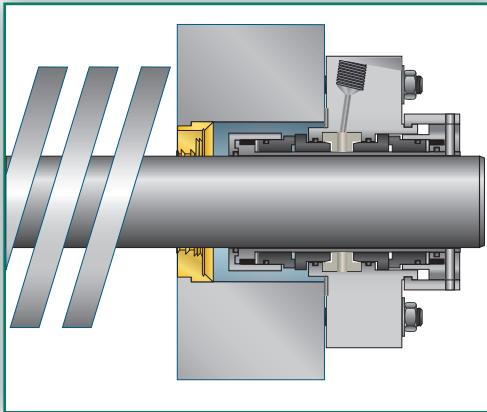

• Application Info

- Brake Slushing pump
- Product: Methanol with 5% pulp
- Shaft size: 35mm / 1.377"
- 3600 RPM

• Problem

- Pulp was plugging seal cavity
- Short seal life
- Double seal was only lasting six months
- Annual repair cost of \$9,300



• Solution

- SpiralTrac™ Version D Type A installed with Chesterton 280™ double mechanical seal
- #280 TC/TC/TC/CB, EP O-ring

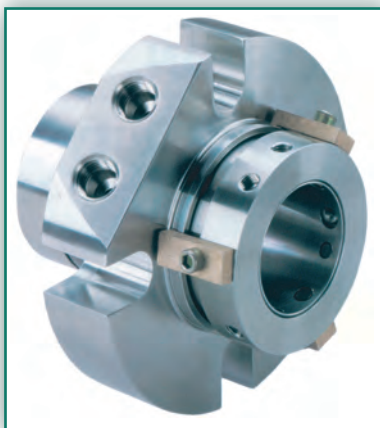

• Result

- SpiralTrac prevents pulp from plugging seal cavity
- Seal life has been extended to over three years
- Annual cost savings of \$4,500

