

Application Success Story:

Industry: Pulp and Paper
Product: Black Liquor
Sealing Solution: Packing

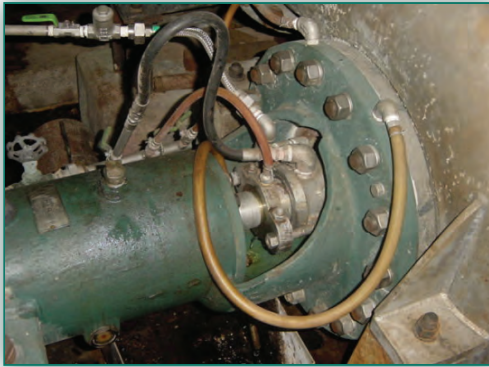

• Application Info

- C4 Top Circulation Pump
- Product: Black Liquor

• Problem

- Packing used with no flush
- Packing had to be replaced every 3 months
- Excessive hot black liquor leakage
- Unscheduled shut downs 4-5 times/yr
- Annual repair cost of \$7,600

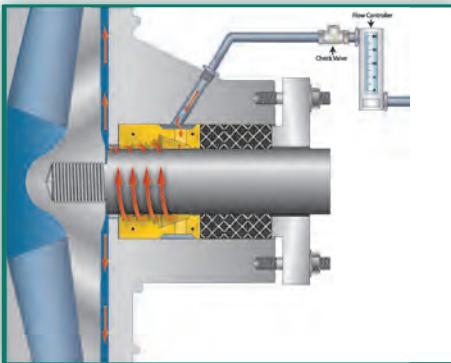

• Solution

- SpiralTrac Version P installed with Chesterton 1400R[®] packing running with minimum flush 0.80 gpm / 3L/min

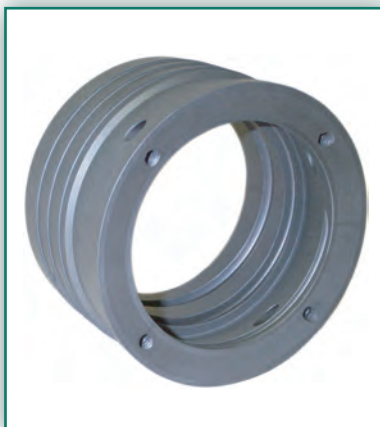

• Result

- Pump has run one year without trouble
- No more unexpected shut downs
- Annual cost savings of \$5,500

