

## Application Success Story:

Industry: **Pharmaceutical**  
Product: **Lime Slurry**  
Sealing Solution: **Mechanical Seal**



### • Application Info

- Product: Lime Slurry used for water treatment
- Solids: 20%
- Pump: DIGÉP model SZ 50/32-200

### • Problem

- This is an intermittent operation, when the pump stops flush is introduced for one minute to clean the seal cavity
- The previous sealing setup was only lasting 300 hours with full uncontrolled flush



### • Solution

- **SpiralTrac**<sup>TM</sup> Version N Type I with a Chesterton 155 TC/CB-EP (Standard) @ 30 mm shaft size

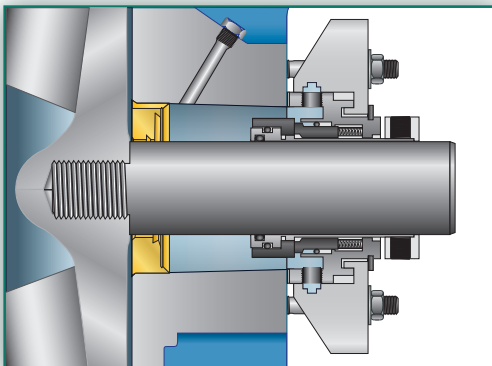

### • Result

- The seal life has increased from 300 hours to 4654 hours
- The customer is extremely happy with this success and wants to install the same solution in the rest of the pumps

