



Application Success Story:

Industry: Pulp & Paper

Product: Pulp

Sealing Solution: Packing

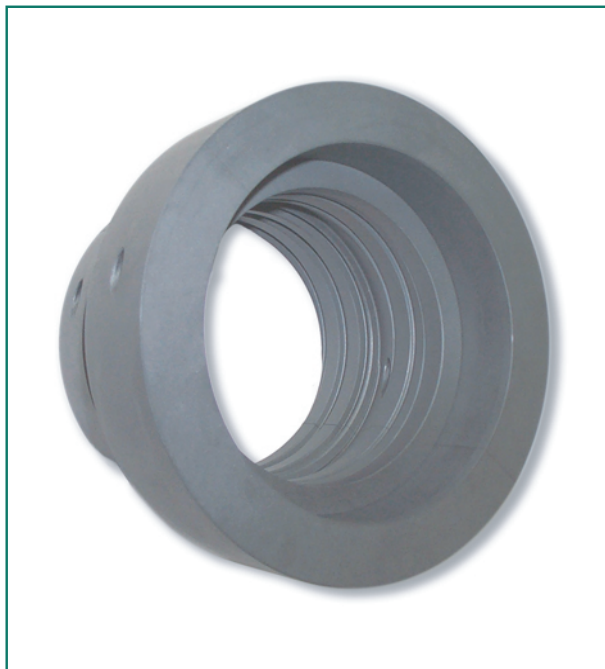
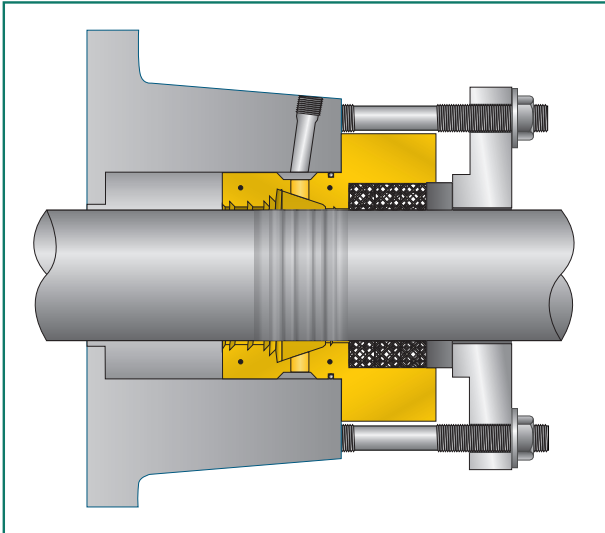

- **Application Info**
 - Lightnin Mixer
- **Problem**
 - Shaft worn badly
 - Excessive Flush
 - Excessive Product Leakage
 - \$8000.00 to replace shaft and bearings plus downtime costs
- **Solution**
 - **SpiralTrac™** Seal Adaptor designed to move the packing to an area of the shaft with less wear and 3 rings of Chesterton high quality packing
- **Result**
 - Doubled the life of the shaft at only 1/8 of the cost of a new one
 - Now only Clean Leakage at the gland



EnviroSeal
Engineering Products Limited

2456 Rocky Lake Drive
Waverley, Nova Scotia B2R 1R6 CANADA
(902) 861-3464 Fax: (902) 861-3522
Email: sales@enviroseal.ca
Website: www.enviroseal.ca

DISTRIBUTED BY: