



Application Success Story:

Industry: **Manufacturing**

Product: **Detergent**

Sealing Solution: **Mechanical Seal**



• Application Info

- Pump: Durco Mark III Group I
- Product: Pigments for Detergents
- 40% Solids

• Problem

- Mechanical seal would pack solid and start to leak within hours
- High maintenance costs

• Solution

- **SpiralTrac™ Version N Type I** installed with a cartridge seal

• Result

- Pump has run totally leak free for more than 45 days

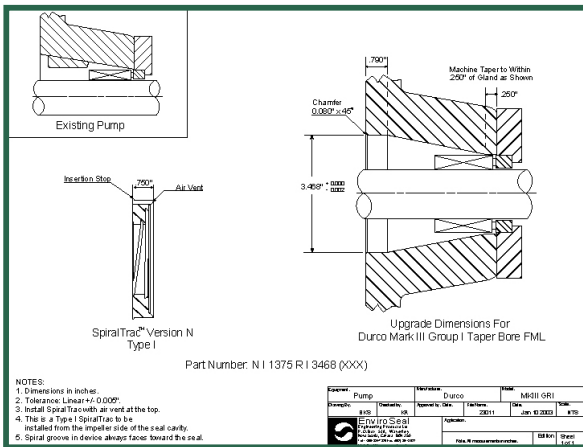

2456 Rocky Lake Drive
Waverley, Nova Scotia B2R 1R6 CANADA
(902) 861-3464 Fax: (902) 861-3522
Email: sales@enviroseal.ca
Website: www.enviroseal.ca

DISTRIBUTED BY: