



Application Success Story:

Industry: Pulp & Paper

Product: Sludge

Sealing Solution: Mechanical Seal

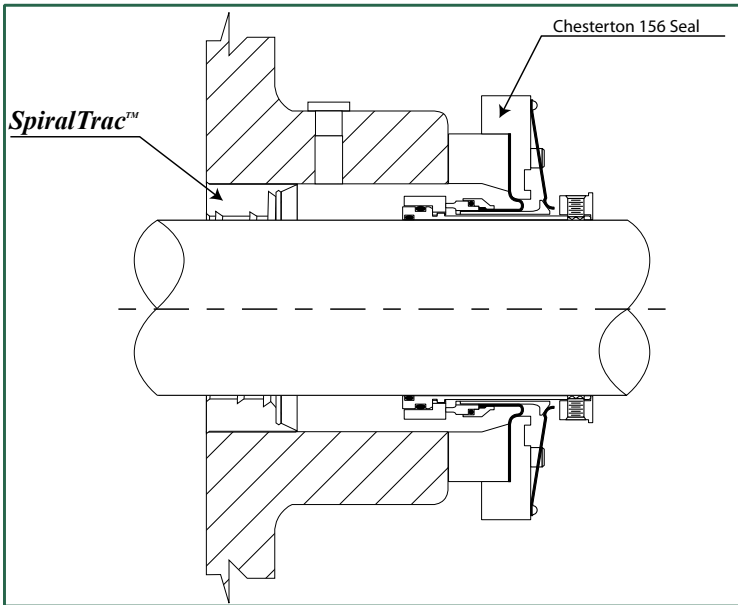

- **Problem**

- No flush available
- Short seal life; lasted 3 days

- **Solution**

- **SpiralTrac™ Environmental Controller** installed with a 156 mechanical seal
- No flush needed
- Pump wore out 10 months later with the seal still running
- Dramatically increased MTBR
- Dramatically decreased operating and maintenance costs
- Customer very happy

Equipment Info

- Clarifier Underflow
- Mission 3x4-R11
 - 1800 rpm
 - Pumping thick effluent sludge



EnviroSeal
Engineering Products Limited

2456 Rocky Lake Drive
Waverley, Nova Scotia B2R 1R6 CANADA
(902) 861-3464 Fax: (902) 861-3522
Email: sales@enviroseal.ca
Website: www.enviroseal.ca

DISTRIBUTED BY:

SpiralTrac is a trademark of EnviroSeal Engineering Products Ltd

ST01283-140200