

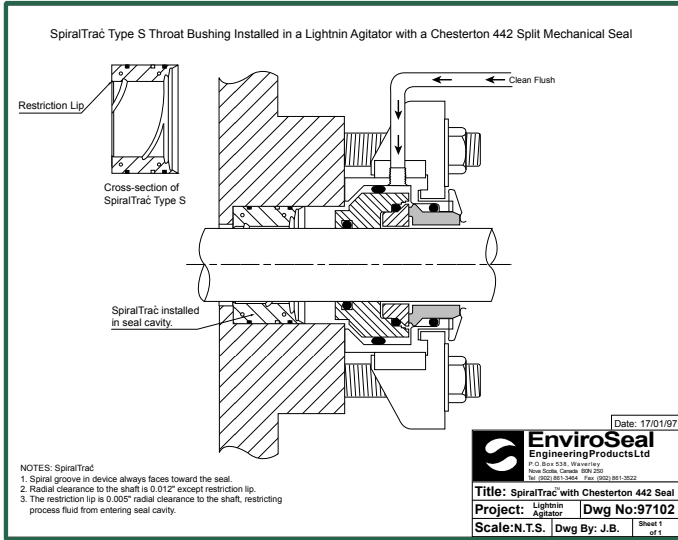

# Application Success Story:

Industry: Pulp & Paper  
 Product: Paper Stock  
 Sealing Solution: Mechanical Seal



## Equipment Info

- Lightnin Agitator Blow Tank

## • Problem

- Excessive flush and leakage with conventional packing
- Poor packing life, 3 to 6 months
- Severe sleeve wear
- High maintenance costs

## • Solution

- **SpiralTrac™ Version F Type S** installed with a 442 split mechanical seal
- Greatly reduced flush rate 8-10 GPH / 30-49 LPH and no leakage
- Dramatically increased MTBR
- Dramatically decreased operating and maintenance costs
- Customer very happy



2456 Rocky Lake Drive  
 Waverley, Nova Scotia B2R 1R6 CANADA  
 (902) 861-3464 Fax: (902) 861-3522  
 Email: sales@enviroseal.ca  
 Website: www.enviroseal.ca

DISTRIBUTED BY:

SpiralTrac is a trademark of EnviroSeal Engineering Products

ST01269-130100