



Application Success Story:

Industry: Hydro

Product: Water

Sealing Solution: Packing

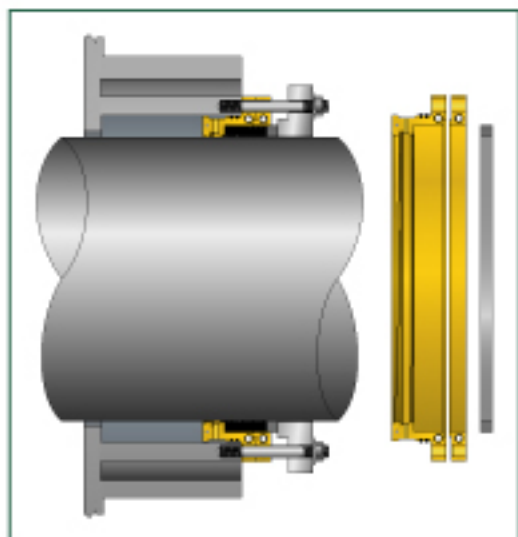

- **Application Info**

- Product: Water
- Temp: Ambient

- **Problem**

- Shaft worn severely
- Cost for resleeving the shaft would be approximately \$120,000
- Only able to run at 50% for the past 12 years due to excessive leakage



- **Solution**

- **SpiralTrac™** Seal Adaptor for packing which was designed to move the packing to an area of the shaft sleeve with no wear
- Material: ESC
- Chesterton 370 packing

- **Result**

- Doubled the life of the shaft
- Now able to run equipment at 90% -100% of full capacity for the first time in 12 years
- Very minimal leakage



EnviroSeal
Engineering Products Limited

1310 Rocky Lake Drive
Waverley, Nova Scotia B2R 1R6 CANADA
(902) 861-3464 Fax: (902) 861-3522
Email: sales@enviroseal.ca
Website: www.enviroseal.ca

DISTRIBUTED BY:

Copyright © 2004
EnviroSeal Engineering Products Ltd

ST04553-08005