



Application Success Story:

Industry: Chemical

Product: Water

Sealing Solution: Mechanical Seal



- **Application Info**

- Split Case Ingersoll Rand Pumps in the HVAC Dept of a large Pharmaceutical Plant
- Product - Water
- Temp 40-60°F / 4-15°C



- **Problem**

- They have very high iron content with trace solids in their chilled water system and tower pumps

- **Solution**

- **SpiralTrac™** Seal Adaptor
- Material: ESC
- Chesterton 442 split mechanical seal

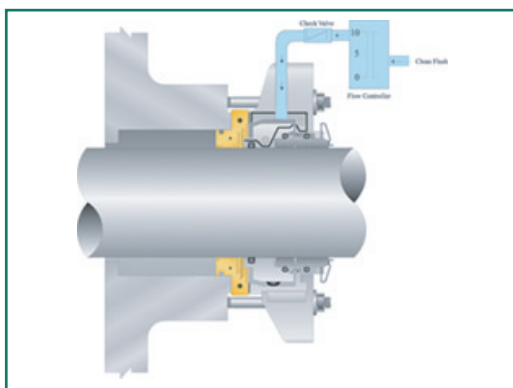

- **Result**

- These SpiralTrac Seal Adaptors have been running trouble free for over two years



EnviroSeal
Engineering Products Limited

1310 Rocky Lake Drive
Waverley, Nova Scotia B2R 1R6 CANADA
(902) 861-3464 Fax: (902) 861-3522
Email: sales@enviroseal.ca
Website: www.enviroseal.ca

DISTRIBUTED BY:

Copyright © 2004
EnviroSeal Engineering Products Ltd

ST01552-210105