



Application Success Story:

Industry: **Manufacturing**
 Product: **Aluminum**
 Sealing Solution: **Mechanical Seal**



• Problem

- Very tough application
- "Very abrasive liquor"
- Pumps and seals lasting only 3 months
- High maintenance costs

• Solution

- **SealMate™** installed in LD-17 pump with a 180-15 seal
- Now running flush free
- 21 pump and seal combinations installed and no failures in 15 months - a 500% increase over previous installations

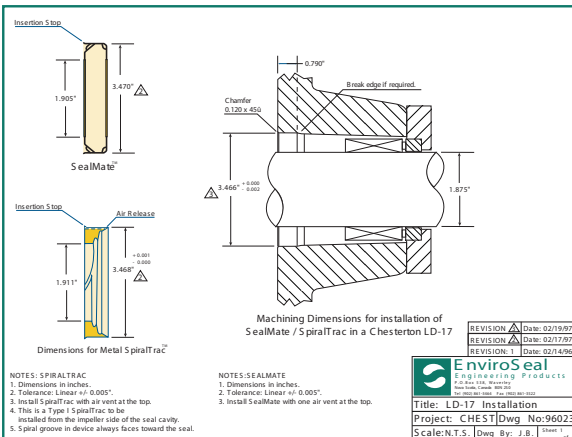

• Equipment Info

- Chesterton Pump
- LD-17



1310 Rocky Lake Drive/P.O. Box 538
 Waverley, Nova Scotia B0N 2S0 CANADA
 (902) 861-3464 Fax: (902) 861-3522
 Email: sales@enviroseal.ca
 Website: www.enviroseal.ca

DISTRIBUTED BY:

U.S. Patents #5,553,868 #5,167,418
 Euro. Pat. App. 0 912 848

ST01419-010600