

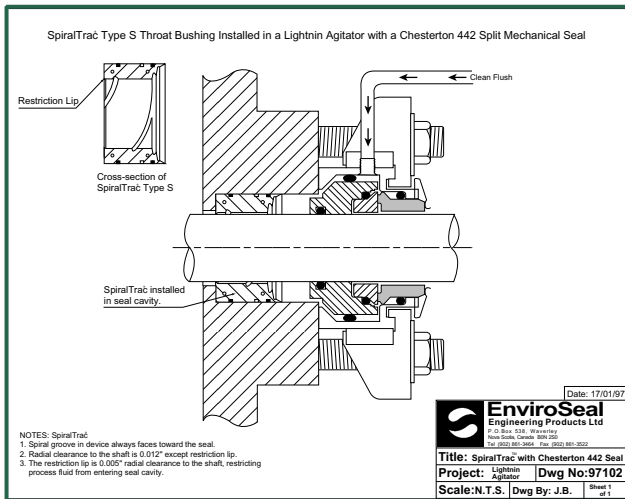

## Application Success Story:

Industry: **Pulp & Paper**  
 Product: **Paper Stock**  
 Sealing Solution: **Mechanical Seal**



### • Problem

- Excessive flush and leakage with conventional packing
- Poor packing life, 3 to 6 months
- Severe sleeve wear
- High maintenance costs

### • Solution

- **SpiralTrac™ Version F Type S** installed with a 442 split mechanical seal
- Greatly reduced flush rate 8-10 GPH / 30-49 LPH and no leakage
- Dramatically increased MTBR
- Dramatically decreased operating and maintenance costs
- Customer very happy

## Equipment Info

- Lightnin Agitator Blow Tank



1310 Rocky Lake Drive/P.O. Box 538  
 Waverley, Nova Scotia B0N 2S0 CANADA  
 (902) 861-3464 Fax: (902) 861-3522  
 Email: sales@enviroseal.ca  
 Website: www.enviroseal.ca

DISTRIBUTED BY:

U.S. Patents #5,553,868 #5,167,418  
 Euro. Pat. App. 0 912 848

ST01269-130100