

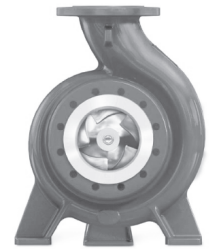

# Equipment Specific Bulletin



## SULZER ScanPump



- SpiralTrac** Dramatically reduces the high costs associated with sealing your equipment.
- SpiralTrac** Increases MTBR.
- SpiralTrac** Eliminates seal and cavity erosion.
- SpiralTrac** Enables seals to operate longer in applications not possible before.
- SpiralTrac** Reduce or Eliminate Flush.
- SpiralTrac** Is easy to install.

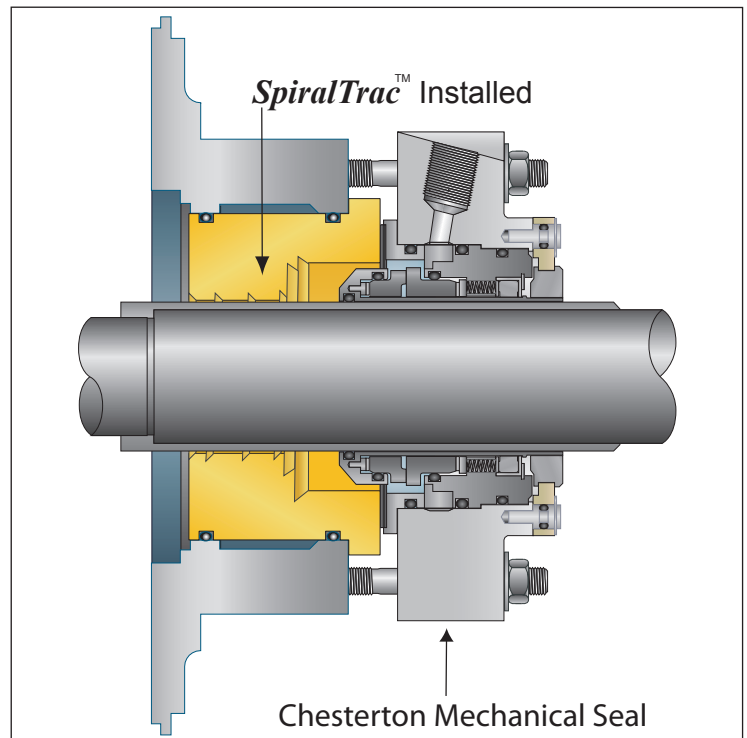
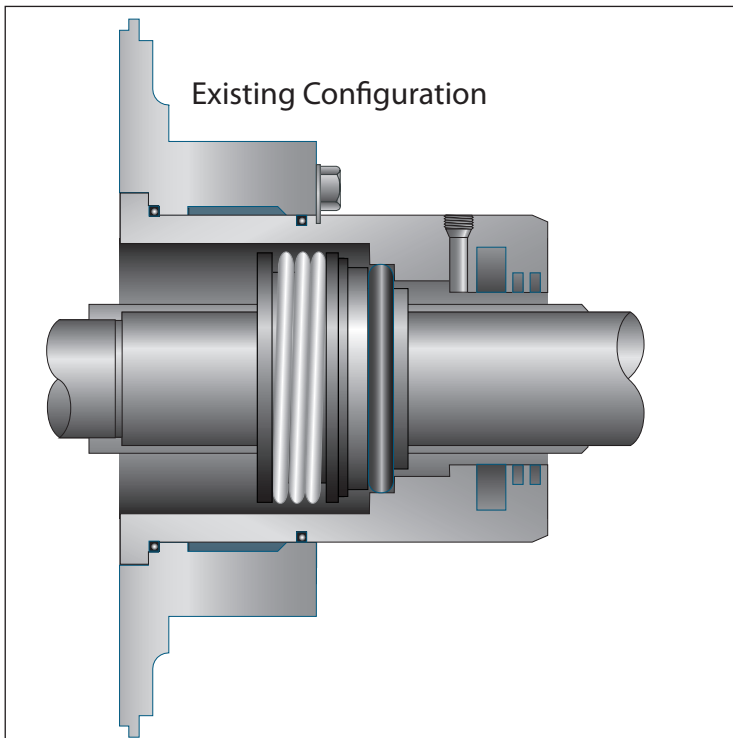

### SpiralTrac Enhanced Environment

Results that will surpass anything you have experienced in the past.

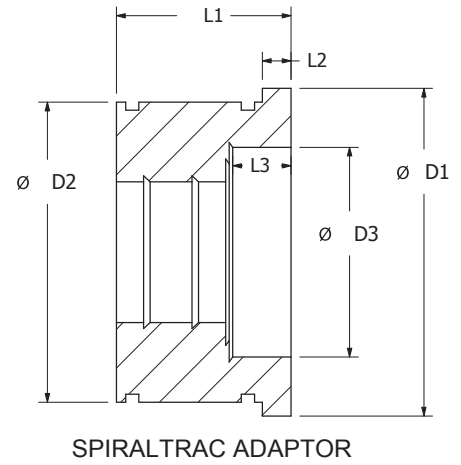
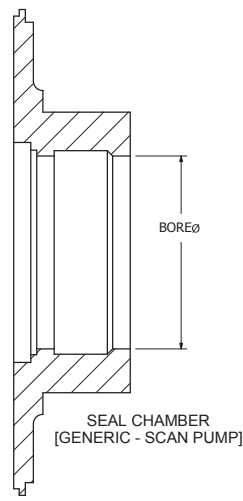
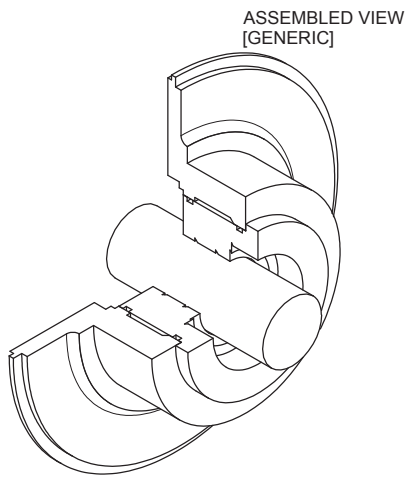

## SCANPUMP CHART

For use with 150 155 180 S10 Seals			Adaptor Part Number		Flange OD	Bore OD		OAL	Flange Length	
BEARING UNIT	SHAFT / SLEEVE Ø	BORE Ø	SINGLE SPIRAL <sup>Note:1</sup>	DOUBLE SPIRAL <sup>Note:2</sup>	Ø D1	Ø D2	Ø D3	L1	L2	L3
1	38 mm	95mm	AFN10-0758_(XXX)	AFN10-0765_(XXX)	103mm	94.75mm	61 mm	60.76 mm	10mm	23.4 mm
1	40 mm	95mm	AFN10-0759_(XXX)	AFN10-0766_(XXX)	103 mm	94.75 mm	68 mm	60.76 mm	10 mm	23.4 mm
2	48 mm	105 mm	AFN10-0760_(XXX)	AFN10-0767_(XXX)	114 mm	104.75 mm	73 mm	60.76 mm	10 mm	23.4 mm
2	50 mm	105 mm	AFN10-0761_(XXX)	AFN10-0768_(XXX)	114 mm	104.75 mm	78 mm	60.76 mm	10 mm	23.4 mm
3	65 mm	130 mm	AFN10-0762_(XXX)	AFN10-0769_(XXX)	140 mm	129.75 mm	100 mm	60.76 mm	10 mm	23.4 mm
4	75 mm	140 mm	AFN10-0763_(XXX)	AFN10-0770_(XXX)	150 mm	139.75 mm	113 mm	70.00 mm	10 mm	35.1 mm
5	100 mm	170 mm	AFN10-0764_(XXX)	AFN10-0771_(XXX)	180 mm	169.75 mm	138 mm	70.00 mm	10 mm	35.1 mm

For use with 250 255 280 S20 Seals			Adaptor Part Number	Flange OD	Bore OD		OAL	Flange Length Double Spiral	
BEARING UNIT	SHAFT / SLEEVE Ø	BORE Ø	DOUBLE SPIRAL <sup>Note:3</sup>	Ø D1	Ø D2	Ø D3	L1	L2	L3
1	38 mm	95mm	AFN10-0779_(XXX)	103mm	94.75mm	61 mm	70.76 mm	20 mm	50 mm
1	40 mm	95mm	AFN10-0780_(XXX)	103 mm	94.75 mm	61 mm	70.76 mm	20 mm	50 mm
2	48 mm	105 mm	AFN10-0781_(XXX)	114 mm	104.75 mm	73 mm	70.76 mm	20 mm	50 mm
2	50 mm	105 mm	AFN10-0782_(XXX)	114 mm	104.75 mm	71 mm	70.76 mm	20 mm	50 mm
3	65 mm	130 mm	AFN10-0783_(XXX)	140 mm	129.75 mm	93 mm	70.76 mm	20 mm	52 mm
4	75 mm	140 mm	AFN10-0784_(XXX)	150 mm	139.75 mm	112 mm	80.00 mm	20 mm	58.2 mm
5	100 mm	170 mm	AFN10-0785_(XXX)	180 mm	169.75 mm	137 mm	80.00 mm	20 mm	58.2 mm

Note: 1 Recommended for use with flush  
 Note: 2 Call EnviroSeal for flush recommendation  
 Note: 3 No flush required

The information contained in this bulletin is accurate at time of print. The purchaser is responsible for ensuring the dimensions, quantity and applications suitability meet end-user requirements. Most products are "manufactured to order"; therefore, EnviroSeal Engineering Products Ltd. retains the right to individually authorize returns based upon the potential for resale of the products within a reasonable period of time.

**Questions:** Ask your local Distributor or contact EnviroSeal directly.



Copyright © 2011  
 EnviroSeal Engineering Products Ltd

Tel: (902) 861-3464  
 Fax: (902) 861-3522  
 Tel: 1-800-884-7325 (North America only)  
 www.enviroseal.ca  
 Email: sales@enviroseal.ca

ST01681-190111